

# V series submersible cutting pump ( Stainless steel motor housing )

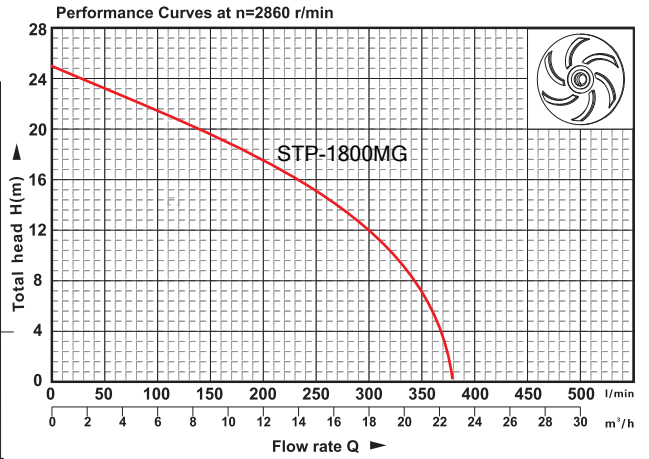
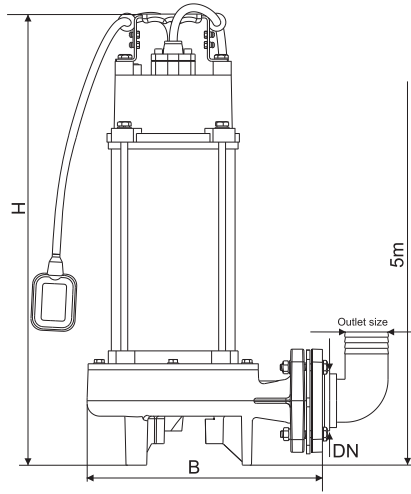

## Technical Parameter

Model	Power (kw)	Outlet size (mm)	Max. flow (L/min)	Max. head (m)	G.W. (kg)	Package size (cm)	DN	B (mm)	H (mm)
STP-1800MG	1.8	50	360	25	37.6	34*23*55	G2"	275	525

## STP-1500MG

## Exploded Views

No	Name	Material	No	Name	Material
1	Float switch	Combination part	31	Lower bearing	Combination part
2	Hex cap screw	11	32	Key	Fe360A
3	Cable protector	ABS/ Epoxy	33	Motor housing	11
4	Cable clamp	11	34	Hex head bolt	11
5	Phillips screw	11	35	Oil chamber	200
6	Hexagonal nut	11	36	O-ring	NBR
7	Cable gland	NR	37	Mechanical seal	Graphite/ceramics
8	Seal washer	NBR	38	O-ring	NBR
9	Hex head bolt	11	39	Oil chamber cover	200
10	Washer	11	40	Oil seal	Combination part
11	Handle	11	41	Hex cap screw	11
12	Power cord	Combination part	42	Impeller	200
13	Button head screw	11	43	Nut	CuZn40
14	O-ring	NBR	44	Pump casing	200
15	Hex head bolt	11	45	Cutter head	17-4PH
16	Spring washer	11	46	Hex cap screw	11
17	Capacitor cover	200	47	Rotary cutter	17-4PH
18	Capacitor	Combination part	48	Hex cap screw	11
19	O-ring	NBR	49	Outlet connector	ABS
20	Wire protector	NBR	50	O-ring	NBR
21	Phillips screw	CuZn40	51	Hex head bolt	11
22	Serrated lock washer	11	52	Flange	200
23	Washer	CuZn40	53	Rubber gasket	NBR
24	O-ring	NBR	54	Hexagonal nut	11
25	Motor cover	200			
26	O-ring	NBR			
27	Wave washer	1566			
28	Upper bearing	Combination part			
29	Motor protector	Combination part			
30	Rotor	Combination part			